



PAOLO CASTELLI



Oggetti d'Autore: omaggio a Morandi

Oggetti d'Autore: omaggio a Morandi

Objets d'Auteur: tribute to Morandi



Paolo Castelli firma per Istituzione Bologna Musei la capsule Oggetti d'autore: Omaggio a Morandi, oggetti e complementi si vestono d'arte, di colore, e di creatività. Per dare nuove energie all'interior decoration, con un forte accento lirico e poetico.

Un sodalizio creativo, quello tra il designer e imprenditore emiliano, Paolo Castelli, e l'Istituzione Bologna Musei, iniziato "silenziosamente" nel 2009, durante i lavori di riallestimento di Casa Morandi, la dimora dell'artista in via Fondazza 36 dove Morandi visse con la madre e le sorelle dal 1910 al 1964. Esattamente 45 anni dalla morte dell'artista, un incontro fortuito, quello tra Paolo Castelli e Istituzione Bologna Musei, da cui ha preso forma una collaborazione di successo.

Paolo Castelli designs the Objets d'Auteur: tribute to Morandi capsule for Istituzione Bologna Musei, objects and accessories in an artistic, colourful and creative guise. Bringing new energy to interior decoration, with a strong lyrical and poetic accent.

A creative partnership between the designer and entrepreneur from Emilia, Paolo Castelli, and Istituzione Bologna Musei, which began "silently" in 2009, during the refurbishment of Casa Morandi, the artist's home in Via Fondazza 36, where Morandi lived with his mother and sisters from 1910 to 1964. Exactly 45 years after the artist's death, a fortuitous meeting between Paolo Castelli and Istituzione Bologna Musei, which led to the development of a successful collaboration.



PAOLO CASTELLI



La collezione si ispira a Giorgio Morandi e alla sua poetica: a partire dagli oggetti presenti nello studio, per Morandi centro di un'osservazione minuziosa, contemplativa e reiterata nel tempo, per soffermarsi sugli elementi formali e cromatici di questi protagonisti assoluti della ricerca artistica morandiana.

Nasce così una collezione di oggetti permeati di sofisticata eleganza, che raccontano mondi simbolici con decori e palette mai eccessivi. Da Casa Morandi alle nostre case, questa collezione ci propone accessori e complementi d'arredo con un forte valore identitario.

I vasi di Morandi, le sue bottiglie, le sue ciotole, ma anche i suoi arredi come il letto e il cavalletto assurgono, così, a muse che ispirano le più originali e creative rielaborazioni in chiave contemporanea, dando vita a creazioni dal sapore fortemente artigianale e che esaltano forme e colori, coniugando estetica ed etica.

The collection is inspired by the artist and his poetics: starting with the objects in the studio, the hub of Morandi's meticulous observation, contemplative and repeated over time, to look at the formal and chromatic elements of these absolute protagonists of Morandi's artistic research. The result is a collection of objects permeated with sophisticated elegance, telling the stories of symbolic worlds with understated decorations and colour palettes. From Casa Morandi to our own homes, this collection offers us accessories and furnishing elements with a strong identity.

Morandi's vases, bottles and bowls, but also his furniture, like the bed and easel, are elevated to the status of muses that inspire the most original and creative contemporary reinterpretations, generating creations with a strongly artisan flavour that enhance shapes and colours, combining aesthetics and ethics.

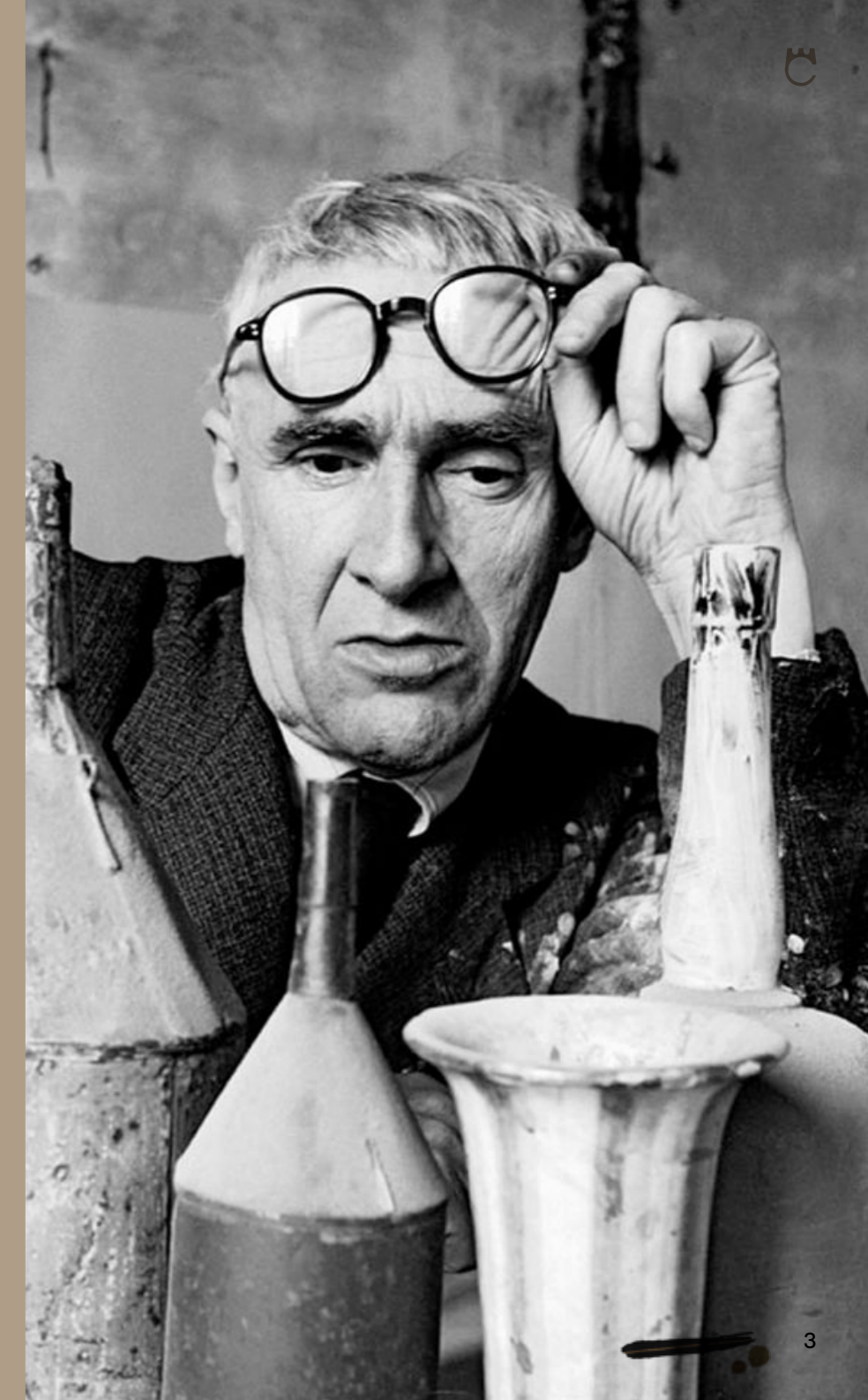

Strapuntino

Tavolinetto pieghevole con manico in legno tinto noce con dettagli in metallo in finitura bronzo opaco. Seduta in tessuto.

Small wooden folding table with handle in walnut-stained finish. Metal details in matt bronzed brass. Seat in fabric.

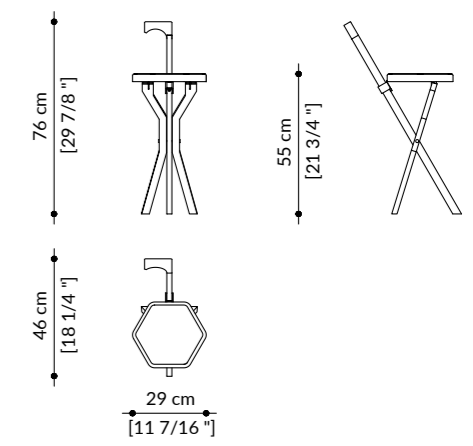

STRAPUNTINO | SED.MORA.001
 Wooden structure walnut stained finish
 Metal details matt bronzed brass finish
 Fabric seat covering col. black or white

Candele d'Autore

Candele in cera realizzate artigianalmente secondo le forme delle tipiche bottiglie Morandiane.

Wax candles handcrafted according to the shapes of the typical Morandi's bottles.



01

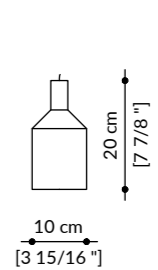

02

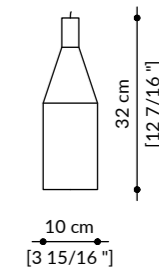

03

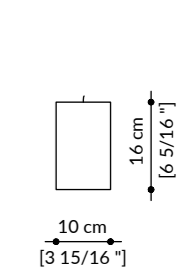

C01 | COM.MORA.CAN.001
Handmade Candle col. Terracotta

C02 | COM.MORA.CAN.002
Handmade Candle col. Ochre

SET 3 CANDLES | COM.MORA.CAN.003
Set of 3 handmade candles: C01 col. Terracotta, C02 col. Ochre, C03 col. Ivory

Appendiabito

Appendiabito in legno
finitura tinto noce con
dettagli in metallo in
finitura bronzo ottone
opaco.

Coat rack in wood walnut-
stained finish with metal
details in matt bronzed
brass.

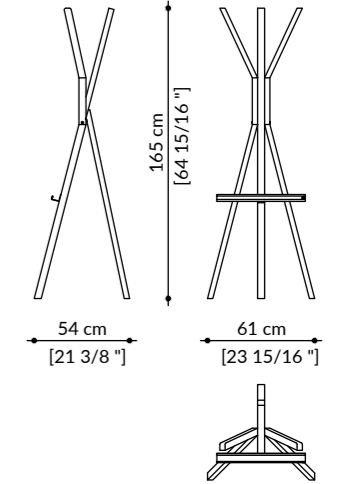

COAT RACK | COM.MORA.HAN
Wooden structure walnut stained finish
Metal details matt bronzed brass finish

Vassoio



Vassoio in legno laccato opaco o rivestito in cuoio color Sabbia. Porta-vassoio in legno massello in finitura tinto noce con dettagli in metallo finitura bronzo ottone opaco. Lacci di supporto in cuoio color Sabbia.

Wooden tray matt lacquered or covered in leather color Sand and tray holder in solid wood in walnut-stained finish with metal details in matt bronzed brass finish. Leather support laces in color Sand.

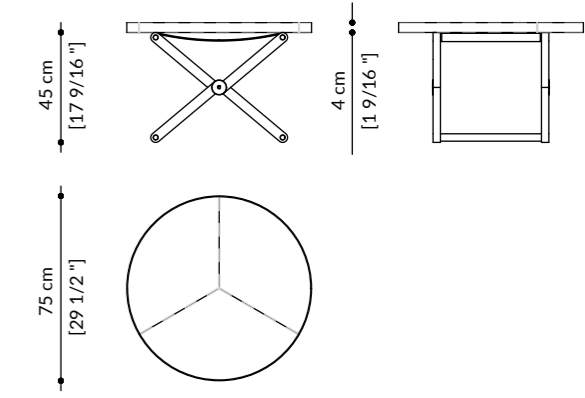

WOODEN BASE | SED.MORA.TRA.001
Wooden base walnut stained finish, feet covered in leather col. Sand
Metal details matt bronzed brass finish

LEATHER TRAY | SED.MORA.TRA.002
Rounded tray covered in leather col. Sand

LAQUERED TRAY | SED.MORA.TRA.003
Rounded tray matt lacquered col. Sand

Scranno



Sgabello pieghevole con struttura in legno finitura tinto noce, dettagli in metallo in finitura bronzo ottone opaco, rivestimento in cuoio col. Sabbia. Cuciture in tinta.

Folding stool in wood -walnut-stained finish- with metal details in matt bronzed brass finish and leather in Sand color with elegant matching stitches.



45 cm
[17 9/16"]

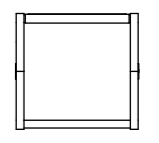
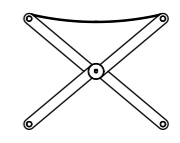

47 cm
[18 11/16"]

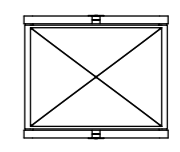

56 cm
[21 7/8"]



SCRANNO | SED.MORA.002
Wooden base walnut stained finish, feet covered in leather col. Sand
Metal details matt bronzed brass finish
Seat made in leather col. Sand

Bicchieri



Set di bicchieri da acqua o vino in vetro borosilicato, decorati in 3 differenti motivi, interamente realizzati a mano e soffiati a bocca. Lavabili in lavastoviglie, utilizzabili anche in microonde. Ogni set è composto da 2 bicchieri per ciascun motivo (6 bicchieri in totale).

Set of water/wine glasses in borosilicate glass, decorated with 3 different motifs entirely handmade and mouth blown. Dishwasher safe, can be used in the microwave oven. Each set is composed of 2 glasses per each motif (6 glasses in total).

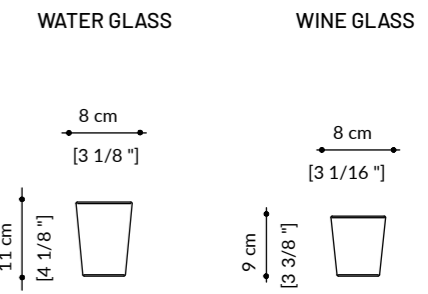

WINE GLASSES SET | COM.MORA.GLA.002
Set of glasses in borosilicate glass. Each set is composed of:
2 glasses with Orange stripe - 2 glasses with Blue-grey stripe - 2 glasses with Multicoloured motif

WATER GLASSES SET | COM.MORA.GLA.001
Set of glasses in borosilicate glass. Each set is composed of:
2 glasses with Orange stripe - 2 glasses with Blue-grey stripe - 2 glasses with Multicoloured motif

Icone silenziose

Vasi decorativi in vetro soffiato di Murano con dettagli in ottone naturale.

Decorative vases in blown Muranese glass with natural brass details.

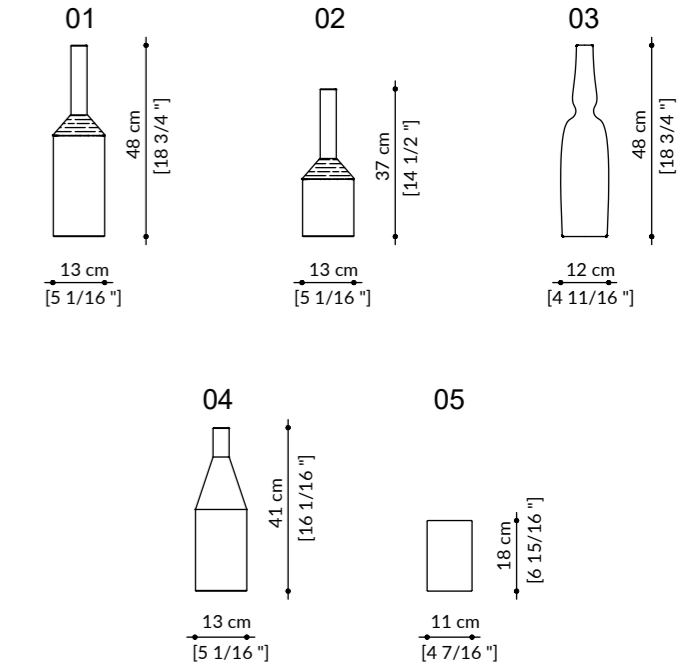

- B01 | COM.MORA.B01**
Handmade Muranese glass. Colour: Grigio Blu (Blue-grey)
Metal details in matt brass
- B02 | COM.MORA.B02**
Handmade Muranese glass. Colour: Fumè (Brown Fumè)
Metal details in matt natural brass
- B03 | COM.MORA.B03**
Handmade Muranese glass. Colour: Petrolio (Petrol green)
- B04 | COM.MORA.B04**
Handmade Muranese glass. Colour: Ambra Medio (Medium Amber)
- B05 | COM.MORA.B05**
Handmade Muranese glass. Colour: Fumè (Brown Fumè)



Icone Luminose

Lampade da terra con struttura in metallo finitura bronzo ottone opaco e cromo, composta da vasi in vetro soffiato di Murano con dettagli in ottone naturale.

Floor lamps made of metal structure in matt bronzed brass finish and chrome. It is composed of vases in Muranese blown glass and natural brass details.

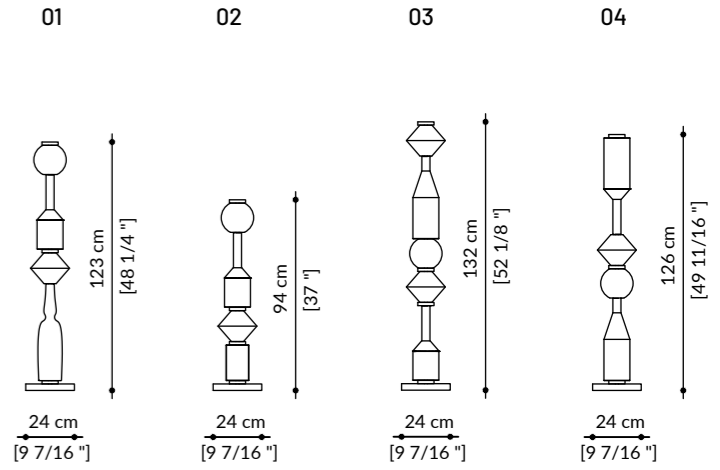

LAMP 01 | ILL.MORA.001
Handmade Muranese glass.
Colour: Verde Petrolio (Petrol green), Ametista (Amethyst), Pagliesco (Champagne), Tabacco (Bronze)
Metal details made in matt natural brass

LAMP 02 | ILL.MORA.002
Handmade Muranese glass. Colour: Ametista (Amethyst), Pagliesco (Champagne), Tabacco (Bronze)
Metal details made in matt natural brass

LAMP 03 | ILL.MORA.003
Handmade Muranese glass. Colour: Ametista (Amethyst), Pagliesco (Champagne), Tabacco (Bronze)
Metal details made in matt natural brass

LAMP 04 | ILL.MORA.004
Handmade Muranese glass.
Colour: Grigio Blu (Blue-grey), Ametista (Amethyst), Pagliesco (Champagne), Tabacco (Bronze)
Metal details made in matt natural brass

Testa

Fernalibri in legno massello spazzolato in finitura tinto noce arricchito sulla faccia piatta da una lamiera metallica sagomata in finitura bronzo ottone opaco.

Bookend in solid wood with walnut-stained finish. Flat side is decorated with metal sheet in matt bronzed brass finish.

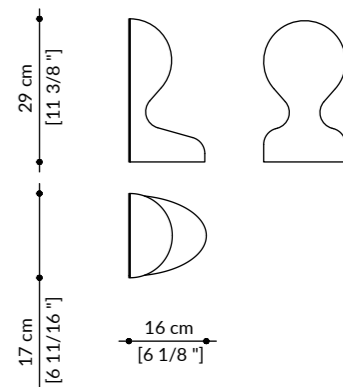

BOOKEND (SINGLE ELEMENT) | COM.MORA.B00
 Wooden structure walnut stained finish
 Metal plate matt bronzed brass finish

Tugurium



Branda pieghevole con struttura in legno finitura tinto noce e dettagli in metallo in finitura bronzo ottone opaco, rivestimento in cuoio col. Sabbia e cuciture in tinta.

Folding cot in wood -walnut-stained finish- with metal details in matt bronzed brass and coating with matching stitches in leather color Sand.

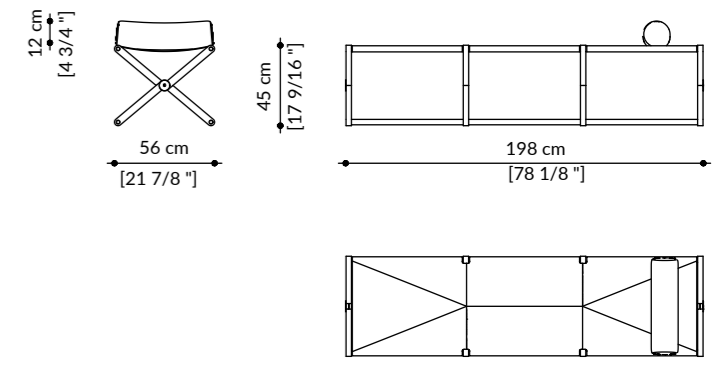

TUGURIUM | NOT.MORA.001
Wooden base walnut stained finish, feet covered in leather col. Sand
Metal details matt bronzed brass finish
Seat made in leather col. Sand

Graffiti

Manufactured by
Wall&decò
elements



Graffiti 1 - Carta da parati modulare che riproduce le silhouettes, i volumi e i colori dell'opera "Natura Morta", dipinta da Morandi nel 1953. Le iconiche bottiglie, che emergono dal fondale chiaro, sono tuttora conservate presso il Museo Casa Morandi di Bologna.
Graffiti 2 - Carta da parati modulare che richiama la delicatezza cromatica della palette morandiana. Nello specifico riproduce le tracce lasciate dai pennelli dell'artista sui fogli di carta che usava appendere al muro come quinte per i set delle sue nature morte.

Graffiti 1 - Modular wallpaper that depicts the silhouettes, volumes and colors of the "Natura morta", painted by Morandi in 1953. The iconic bottles, which emerge from the clear background, are still exposed at the Morandi House Museum in Bologna.
Graffiti 2 - Modular wallpaper that recalls the chromatic delicacy of the Morandian palette. It reproduces the traces left by the artist's brushes on the paper sheets that he used to hang on the wall as a background for the sets of his still life paintings.



GRAFFITI 1 - BOTTLES PATTERN

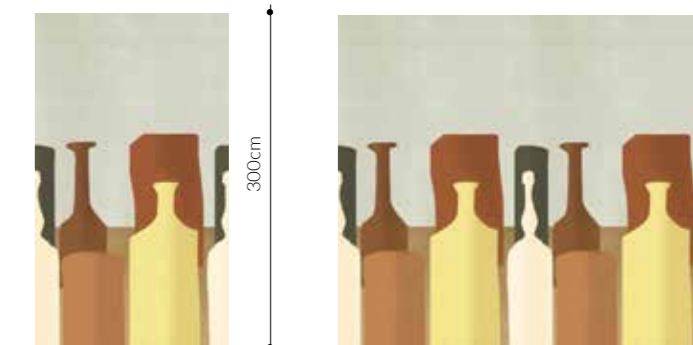

45cm
180cm

GRAFFITI 1 | COM.MORA.WAL.001
Bottles pattern
Roll dim. 45 x 1200 cm
Pattern dim. composition 180 x H 300 cm

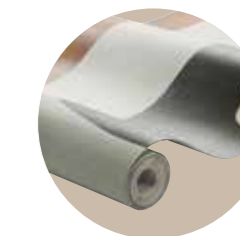

GRAFFITI 2 - BRUSH TRACES PATTERN

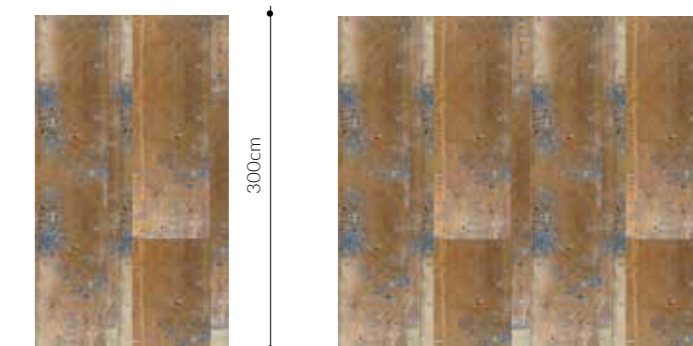

45cm
180cm

GRAFFITI 2 | COM.MORA.WAL.003
Brush traces pattern
Roll dim. 45 x 1200 cm
Pattern dim. composition 180 x H 300 cm



Lampada cono



Lampada in metallo finitura bronzo ottone opaco con paralume in tela di lino. Abbinabile all'appendiabito per comporre una lampada da terra.

Lamp in matt bronzed brass metal finish and lampshade in linen. Matched with coat rack it becomes a floor lamp.

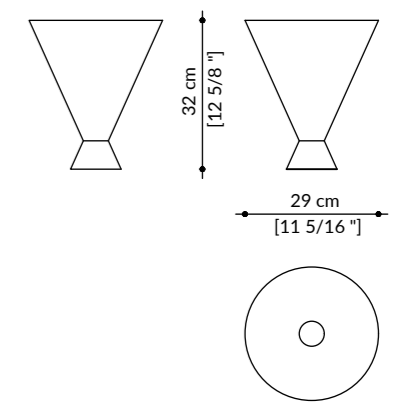

HANGING LAMP | ILL. MORA.HAN
Metal structure matt bronzed brass finish
Lampshade in linen fabric

Sacca del Pittore

Sacca in pelle porta-tablet con manico, tasche esterne portapenne, pennelli e agendina. Cinturino tracolla con fibbia in finitura ottone. Disponibile in pelle colore naturale, fodera interna in tessuto.

Leather tablet bag with handle, external holder for pens, brushes and agenda. Crossbody strap with buckle in brass finish. Available in natural brown leather, with inner fabric lining.

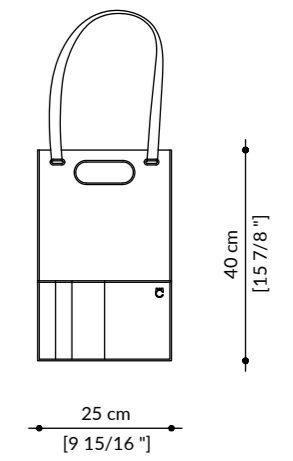

LEATHER BAG | COM.MORA.BAG
Bag made in leather col. Natural
Metal buckle in matt brass
Fabric lining

Piatti d'Autore da portata

Serie di piatti d'autore da portata, in ceramica smaltata rigorosamente dipinte a mano con pennellate della palette di Morandi. Disponibili i piatti piani, i piatti fondi e il set antipasti. Ogni piatto è unico e simula la tavolozza del maestro. Idonei al lavaggio in lavastoviglie e all'uso in microonde.

Series of artistic serving plates in Vietri glazed ceramic hand-decorated with brushstrokes from the Morandi palette. Available dinner plates, soup plates, starter bowls. Each plate is unique and recalls Maestro's color range. Dishwasher and microwave safe.



DINNER PLATE Ø25

Ø25 cm
[Ø 9 13/16"]

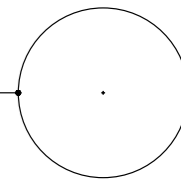

SOUP PLATE Ø18

Ø18 cm
[Ø 7 1/16"]

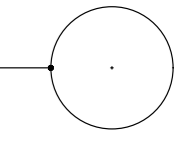

STARTER BOWL Ø14

Ø14 cm
[Ø 5 1/2"]

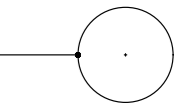

DINNER PLATES SET Ø25 | COM.MORA.PLA.003
Set of 6 plates in hand-decorated ceramic from Vietri - glazed finish
6 different motifs

SOUP PLATES SET Ø18 | COM.MORA.PLA.004
Set of 6 soup plates handmade in ceramic from Vietri - glazed finish
Each set consists of 2 plates for each motif

STARTER BOWLS SET Ø14 | COM.MORA.PLA.003
Set of 6 starter bowls handmade in ceramic from Vietri - glazed finish
6 different motifs

Burattino

Statuetta in legno tinto noce e dettagli e supporto in metallo con finitura in bronzo ottone opaco.

Statuette in walnut-stained wood, metal details and base in matt bronzed brass finish.

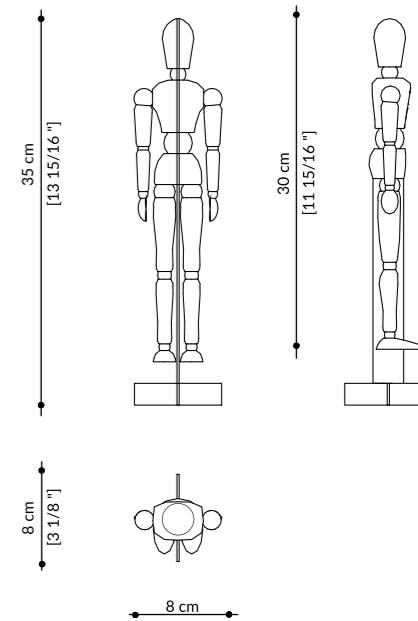

STATUETTE | COM.MORA.PUP.001
Wooden structure walnut stained finish
Support and details in metal matt bronzed brass finish

Cuscini

Cuscini in piuma d'oca, rivestiti in tessuto misto lino color Gog Avorio, impreziositi da sagome delle tipiche bottiglie del Maestro in pelle, fascia perimetrale rivestita in pelle color Sabbia.

Goose down cushions upholstered in natural blended linen color Gog Ivory, embellished with shapes of the typical bottles of the Maestro in leather. Perimeter band made of leather in color Sand.



SQUARE 55

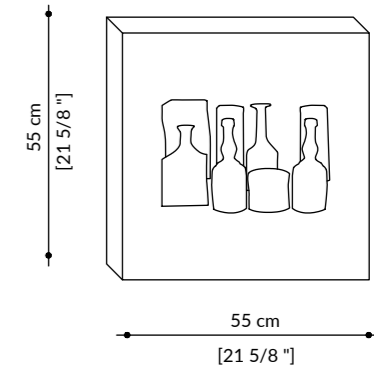

SQUARE 55*55 | COM.MORA.CUS.001
Fabric blended linen col. Gog Ivory
Details in leather- various colours

RECTANGULAR 45*30

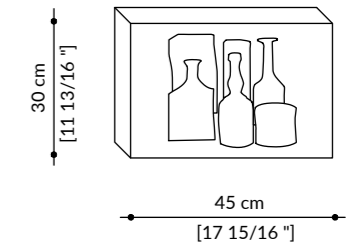

RECTANGULAR 45*30 | COM.MORA.CUS.002
Fabric blended linen col. Gog Ivory
Details in leather- various colours

Piatti d'Autore decorativi



Serie di piatti d'autore decorativi in ceramica di Vietri materica rigorosamente dipinti a mano con pennellate della palette di Morandi. Ogni piatto è unico e simula la tavolozza del maestro.
Piatti disponibili in 2 misure (Ø25 e Ø60cm) con 2 fantasie.

Series of artistic decorative plates in Vietri ceramic in materic finish hand-decorated with brushstrokes from the Morandi palette. Each plate is unique and recalls Maestro's color range.
Plates available in 2 sizes (Ø25 and Ø60cm) with 2 motifs.



Ø25

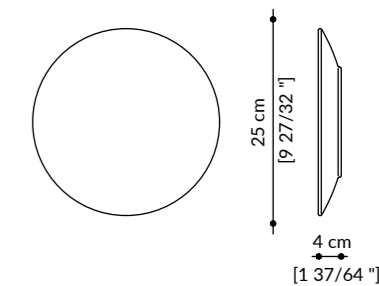

Ø25 | COM.MORA.PLA.001
Materic hand-decorated ceramic from Vietri
Available motifs: stains and brush strokes

Ø60

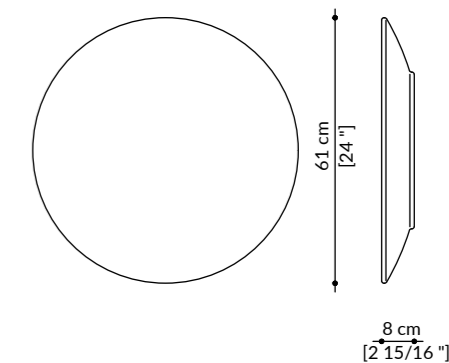

Ø60 | COM.MORA.PLA.002
Materic hand-decorated ceramic from Vietri
Available motifs: stains and brush strokes



Ciotoline decorative

Serie di ciotoline d'autore decorativi in ceramica di Vietri materica rigorosamente dipinti a mano con pennellate della palette di Morandi. Ogni piatto è unico e simula la tavolozza del maestro. Disponibili in 10 fantasie.

Series of artistic decorative bowls in Vietri ceramic in materic finish hand-decorated with brushstrokes from the Morandi palette. Each plate is unique and recalls Maestro's color range. Bowls available in 10 motifs.

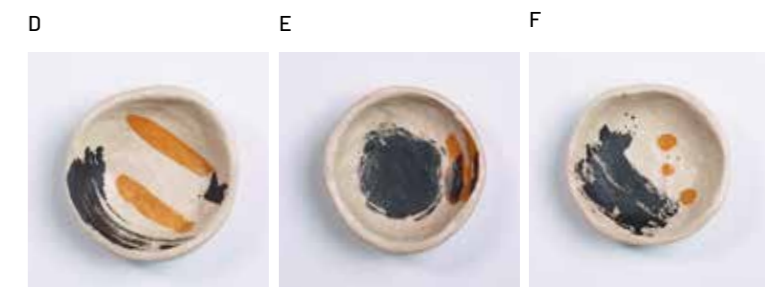
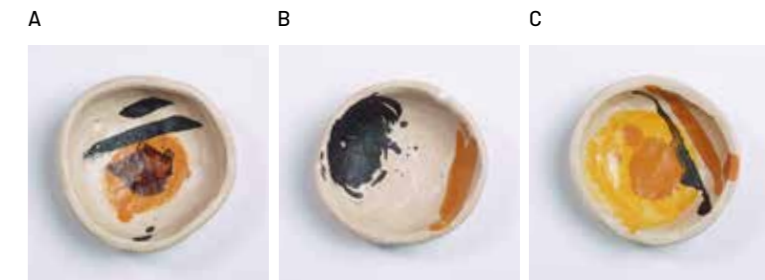

A B C
D E F
G H I
L

DECORATIVE BOWL Ø13 | COM.MORA.PLA.006
Materic hand-decorated ceramic from Vietri
10 different motifs available

Tovaglietta



Tovaglietta in puro lino col. naturale 100% Made in Italy con orlo in contrasto.

Placemat in 100% natural linen Made in Italy with fringed edges that remind frayed canvas.

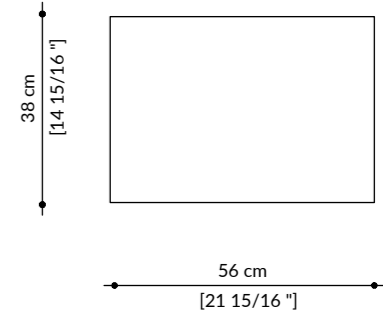
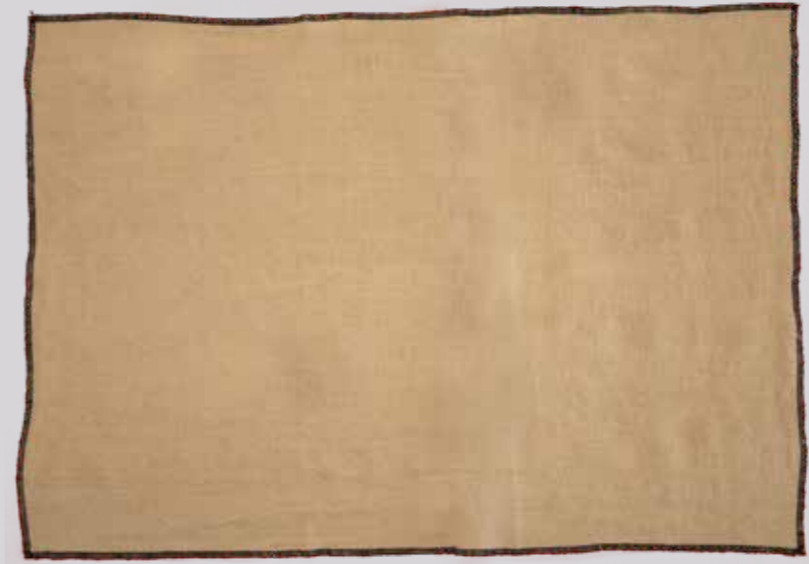

PLACEMAT | COM.MORA.CLO
Placemat made in linen col. Natural

GIORGIO MORANDI BIOGRAFIA

Giorgio Morandi nacque il 20 luglio 1890 a Bologna. Trascorse praticamente tutta la sua vita dedicandosi all'attività di pittore e incisore in un modesto studio-appartamento in Via Fondazza che condivideva con le tre sorelle. Non ebbe mai un vero e proprio atelier, ma viveva e lavorava in una stanza di media grandezza con una finestra che dava su un piccolo cortile, soggetto di numerosi suoi quadri.

Qui si trovavano anche il letto, un vecchio scrittoio, un tavolo da disegno, il cavalletto e poi tutt'intorno, su stretti scaffali, l'arsenale delle semplici cose che conosciamo attraverso le sue nature morte: bottiglie, recipienti, vasi, brocche, utensili da cucina, scatole.

In questa camera-studio l'artista trascorreva le sue ore di riflessione, lavoro e riposo, in un dialogo ininterrotto con la propria realtà. All'infuori di viaggi a Venezia, Firenze o Roma, in occasione delle mostre dei suoi dipinti, e delle escursioni estive a Grizzana, sulle colline dell'Appennino tosco-emiliano, Morandi raramente lasciò Bologna.

Nonostante la sua estrema riservatezza, i suoi dipinti acquistarono fama e vennero richiesti in tutta Europa e in America. Nel 1930 ottenne "per chiara fama" la cattedra di Tecniche dell'incisione presso l'Accademia di Belle Arti di Bologna, dove insegnò per 26 anni.

All'inizio del 1934, durante una presentazione pubblica ad opera di Roberto Longhi, allora professore di Arte Rinascimentale presso l'Università di Bologna, Morandi venne riconosciuto come il maggior pittore vivente in Italia.

Nel 1949 venne presentato nell'importante mostra Twentieth Century Italian Art al Museo di Arte Moderna di New York e nel 1957 gli attribuirono il Gran Premio per la Pittura alla Biennale di São Paulo in Brasile.

Morandi si spense nella casa di Bologna il 18 giugno 1964.

GIORGIO MORANDI BIOGRAPHY

Giorgio Morandi was born in Bologna on 20th July 1890. He spent almost his whole life working as a painter and etcher in a small studio-flat in Via Fondazza that he shared with his three sisters. He never had a proper atelier, but he lived and worked in a medium-size room with a window looking onto a small yard, subject of several of his paintings. In this room there

were also his bed, an old writing table, a drawing table, the easel, and all around, on narrow shelves, the arsenal of the simple things we see in his still lifes: bottles, containers, vases, jugs, kitchen utensils, boxes. In this studio-sleeping room the artist spent his time to

reflect, work, and rest in an uninterrupted dialogue with his own reality. Except for trips to Venice, Florence, or Rome for exhibitions of his paintings, or for summer excursions to Grizzana on the hills of the Tuscan-Emilian Apennines, Morandi scarcely ever left Bologna.

Notwithstanding his extreme reserve, his paintings came to be known and in demand throughout Europe and America. In 1930 he obtained "due to his fame" the professorship of Etching Techniques at the Accademia di Belle Arti of Bologna, where he taught for 26 years.

As early as 1934, in a public address by Roberto Longhi, at that time Professor of Renaissance Art at the University of Bologna, Morandi was recognized as the greatest living painter in Italy. In 1949 he was featured in the seminal exhibition of Twentieth Century Italian Art at the Museum of Modern Art in New York, and in 1957 he was awarded the Grand Prize for Painting at the São Paulo Biennale in Brazil.

Morandi died in his house in Bologna in June 1964.



Loving Giorgio

Oggetti d'autore

omaggio a Giorgio Morandi





Inspiration
THE HOUSE OF ELEGANCE



GREENKISS



PAOLO CASTELLI

La descrizione e le immagini dei prodotti del presente catalogo sono puramente indicative e non possono essere considerate vincolanti ai fini del loro utilizzo. Paolo Castelli S.p.A. si riserva di apportare ai prodotti le modifiche che ritiene più opportune, in qualsiasi momento e senza preavviso. I prodotti, di natura artigianale, possono presentare artefatti materici o irregolarità di lavorazione. Tali irregolarità sono da considerarsi parte integrante della struttura del prodotto stesso e garanzia della lavorazione interamente artigianale. Per ulteriori informazioni sulle caratteristiche tecniche dei prodotti, invitiamo a consultare il sito www.paolocastelli.com dove troverete l'elenco dei contatti a cui rivolgervi.

Descriptions and pictures of the products included in the present catalogue are purely indicative and cannot be considered binding for their final use. Paolo Castelli S.p.A. reserves itself the right to modify its own products without any prior notification. The handmade artisan production can present irregularities due to the manufacturing. These irregularities must be considered essential part of the product itself and guarantee of entirely handcrafted manufacturing. For any further technical information on the products, please visit www.paolocastelli.com where you can find all the contacts you can address to.





PAOLO CASTELLI

BOLOGNA

Contract Office & Showroom

MILAN

Contract Office & Showroom

PARIS

Contract Office & Showroom

LONDON

Contract Office

CARRARA

Marine Division